



basic education

Department:
Basic Education
REPUBLIC OF SOUTH AFRICA

NATIONAL SENIOR CERTIFICATE

GRADE 10

PHYSICAL SCIENCES: PHYSICS (P1)

EXEMPLAR 2012

MARKS: 150

TIME: 2 hours

**This question paper consists of 15 pages, 1 data sheet, an answer sheet
and graph paper.**

INSTRUCTIONS AND INFORMATION

1. Write your name in the appropriate space on the ANSWER BOOK.
2. This question paper consists of TWELVE questions. Answer ALL the questions.
3. You may use a non-programmable calculator.
4. You may use appropriate mathematical instruments.
5. YOU ARE ADVISED TO USE THE ATTACHED DATA SHEETS.
6. Number the answers correctly according to the numbering system used in this question paper.
7. Write neatly and legibly.

QUESTION 1**INSTRUCTIONS**

1. Answer this question on the ANSWER SHEET. [NOTE: The ANSWER SHEET may either be a separate sheet provided as part of your question paper, or printed as part of the ANSWER BOOK.] Write your name in the appropriate space, if a separate ANSWER SHEET is used.
2. Various options are provided as possible answers to the following questions. Choose the answer and make a cross (X) in the block (A–D) next to the question number (1.1–1.10) on the ANSWER SHEET.
3. Do not make any other marks on the ANSWER SHEET. Any calculations or writing that may be necessary when answering this question should be done in the ANSWER BOOK and must be deleted clearly by means of a line drawn across the page.
4. If more than ONE block is marked per question, no marks will be awarded for that answer.

PLACE THE COMPLETED ANSWER SHEET INSIDE THE FRONT COVER OF THE ANSWER BOOK, IF A SEPARATE ANSWER SHEET HAS BEEN USED.

EXAMPLE:

QUESTION: The SI unit of time is ...

- A t.
- B h.
- C s.
- D m.

ANSWER:

A	B	<input checked="" type="checkbox"/>	D
---	---	-------------------------------------	---

[NOTE: This layout may vary, depending on the type of ANSWER SHEET used by the province.]

- 1.1 Which ONE of the following physical quantities is a vector?
- A Time
 - B Speed
 - C Velocity
 - D Distance (2)
- 1.2 A characteristic property of motion at constant acceleration is that the ...
- A change in position per unit time is constant.
 - B change in velocity per unit time is constant.
 - C velocity remains constant for the duration of the motion.
 - D change in position remains constant for the duration of the motion. (2)
- 1.3 In the equation $\Delta x = v_i \Delta t + \frac{1}{2} a \Delta t^2$, the part $\frac{1}{2} a \Delta t^2$ represents the ...
- A time.
 - B velocity.
 - C acceleration.
 - D displacement. (2)
- 1.4 The gravitational potential energy of an object relative to the ground is dependent on the object's ...
- A speed.
 - B position.
 - C velocity.
 - D change in velocity. (2)

1.5 Which ONE of the following statements regarding electromagnetic waves is CORRECT?

In a vacuum all electromagnetic waves have the same ...

- A speed.
- B amplitude.
- C frequency.
- D wavelength. (2)

1.6 A tuning fork is made to vibrate by striking it gently on a rubber stopper.

The sound waves produced are ...

- A transverse waves and require a medium for propagation.
- B transverse waves and require no medium for propagation.
- C longitudinal waves and require a medium for propagation.
- D longitudinal waves and require no medium for propagation. (2)

1.7 Which ONE of the following statements is CORRECT?

All waves ...

- A are transverse.
- B are longitudinal.
- C transmit energy.
- D travel through a vacuum. (2)

1.8 The direction of the magnetic field lines of a magnet is towards its ...

- A south pole.
- B north pole.
- C positive pole.
- D negative pole. (2)

- 1.9 An object which is charged positively has ...
- A lost protons.
 - B lost electrons.
 - C gained protons.
 - D gained electrons. (2)
- 1.10 Which ONE of the following is the unit of measurement for the rate of flow of charge?
- A Ohm
 - B Volt
 - C Ampere
 - D Coulomb (2)
- [20]

ANSWER QUESTIONS 2–12 IN THE ANSWER BOOK. ANSWER QUESTION 4.3 ON THE ATTACHED GRAPH PAPER.

INSTRUCTIONS AND INFORMATION

1. Start EACH question on a NEW page in the ANSWER BOOK.
2. Leave ONE line between two subquestions, for example between QUESTION 2.1 and QUESTION 2.2.
3. Number the answers correctly according to the numbering system used in this question paper.
4. Show ALL formulae and substitutions in ALL calculations.
5. Round off your FINAL numerical answers to a minimum of TWO decimal places.
6. Give brief motivations, discussions, et cetera where required.

QUESTION 2 (Start on a new page.)

A crane lifts a crate vertically upward as shown below.

The total weight lifted is 1 480 N. The crane applies an upward force of 1 550 N. A frictional force of 20 N acts on the crate during lifting.

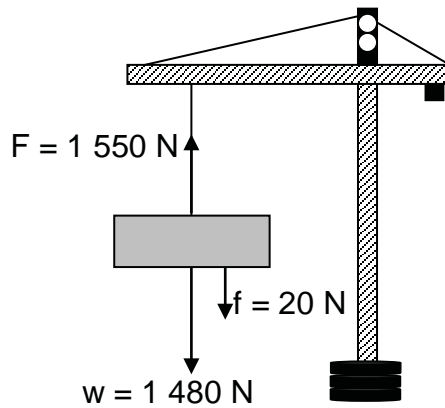

2.1 Define the term *resultant* of a number of forces. (2)

2.2 Calculate the magnitude and direction of the resultant force acting on the crate. (3)

The crate is lifted to a vertical height of 80 m above the ground and then lowered to a height of 20 m above the ground as shown in the diagram below.

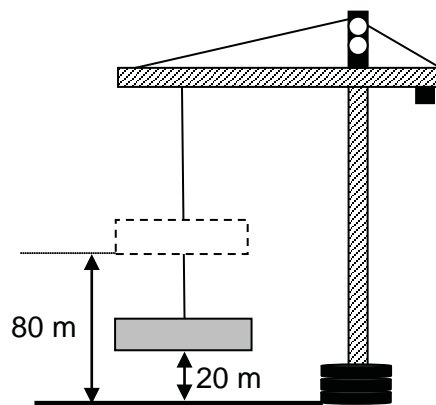

2.3 Calculate the:

2.3.1 Total distance travelled by the crate (2)

2.3.2 Displacement of the crate (1)

[8]

QUESTION 3 (Start on a new page.)

A man runs from point **A** in a straight line along a track **ABCDEFGG**. The velocity-time graph below represents the motion of the man.

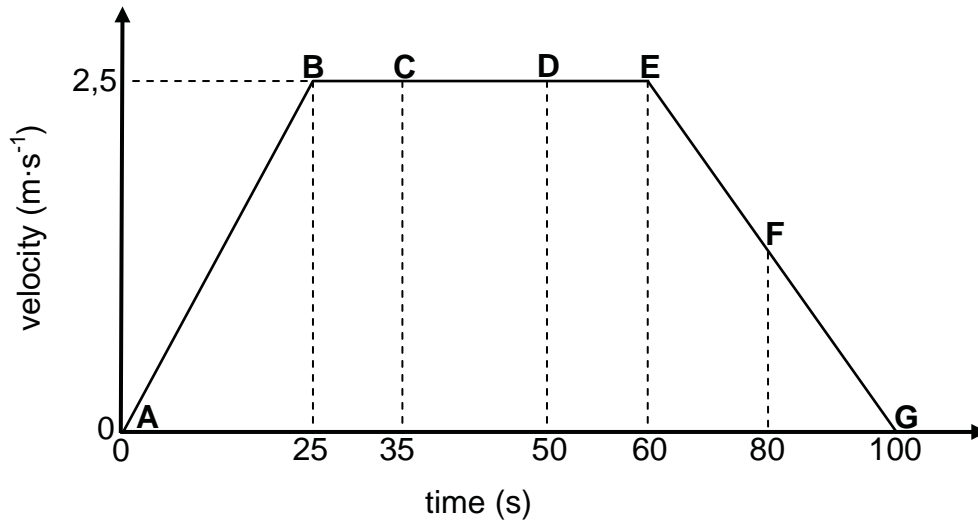

3.1 Using the information on the graph, describe the motion of the man from:

3.1.1 **A to B** (3)

3.1.2 **B to D** (2)

3.2 WITHOUT USING EQUATIONS OF MOTION, calculate the:

3.2.1 Acceleration of the man between **E** and **G** (4)

3.2.2 Distance covered by the man in 100 s (4)

[13]

QUESTION 4 (Start on a new page.)

To investigate the motion of a trolley travelling at uniform acceleration, a runway is set up as shown in the sketch below. The slope of the runway is adjusted before readings are taken.

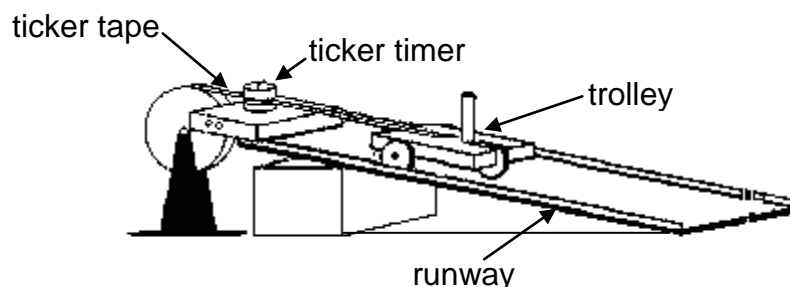

4.1 Give a reason why the slope of the runway has to be adjusted. (2)

The ticker tape is analysed and the displacement (change in position) is measured after each 0,2 s. The table below shows the data obtained.

Time (s)	Position (m)
0,0	0
0,2	0,20
0,4	0,60
0,6	1,20
0,8	2,00
1,0	3,00

4.2 For this investigation, write down the:

4.2.1 Independent variable (1)

4.2.2 Dependent variable (1)

4.3 Draw a graph of position versus time on the attached GRAPH PAPER.

Indicate the following on your graph:

- A suitable heading
- Correct labels on both axes
- An appropriate scale on both axes
- The six plotted points (6)

4.4 What type of motion (UNIFORM MOTION or UNIFORM ACCELERATED MOTION) is represented by the graph drawn in QUESTION 4.3? Give a reason for the answer. (2)

[12]

QUESTION 5 (Start on a new page.)

A delivery van is travelling at a constant speed of $15 \text{ m}\cdot\text{s}^{-1}$ in a $60 \text{ km}\cdot\text{h}^{-1}$ speed zone when the driver sees people walking across a pedestrian crossing 50 m ahead of him. The driver takes exactly one second (1 s) to react before he applies brakes as hard as he can. It takes a further 3 seconds for the van to come to a stop.

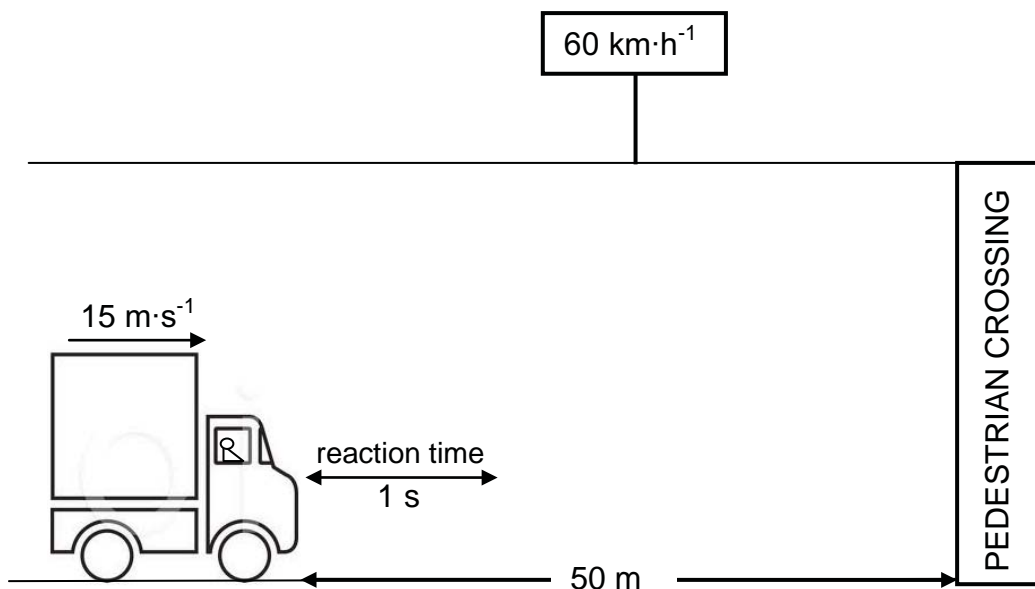

5.1 Complete the following sentence:

The equations of motion are only valid for motion at constant (5.1.1) ... in a (5.1.2) ... line. (2)

5.2 Did the driver of the delivery van exceed the speed limit? Show ALL calculations. (3)

5.3 Calculate the distance that the delivery van travels during the 1 second reaction time. (3)

5.4 Will the van stop before the pedestrian crossing? Show ALL calculations. (6)

5.5 Will the stopping distance of the van INCREASE or DECREASE when the road is wet and slippery?

By referring to velocity and time, briefly explain how you arrived at the answer. (3)

[17]

QUESTION 6 (Start on a new page.)

An object of mass 0,2 kg is released at point **A** and moves along the frictionless section **AC** of a curved track. Along section **CD** it experiences friction and stops at point **D**. The vertical height of point **A** above point **X** on the ground is 0,8 m as shown below.

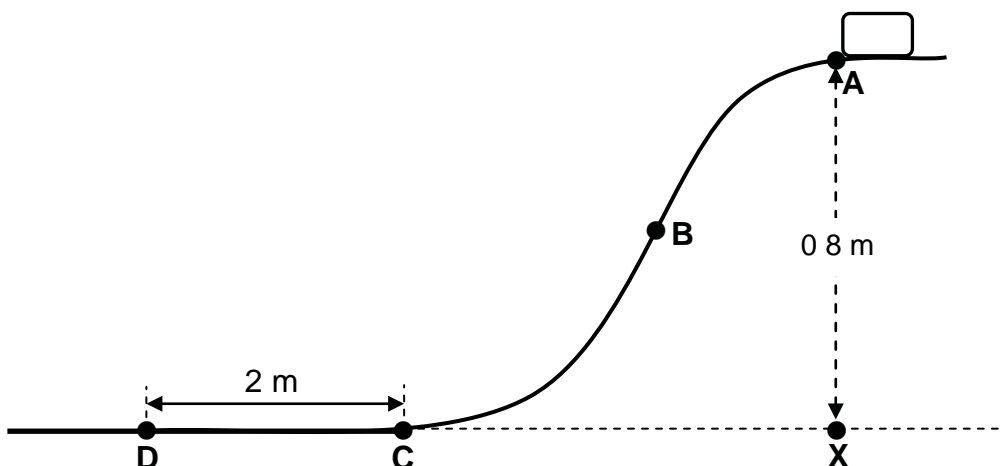

- 6.1 Write down, in words, the *principle of conservation of mechanical energy*. (2)
- 6.2 Calculate the gravitational potential energy of the object at point **A** just before it is released. (3)
- 6.3 At point **B** the speed of the object is $3 \text{ m}\cdot\text{s}^{-1}$. Use the principle of conservation of mechanical energy to calculate the vertical height of point **B** above the ground. (6)
- 6.4 The object reaches point **C** at a velocity of $3,96 \text{ m}\cdot\text{s}^{-1}$.
- 6.4.1 Write down the energy conversion which takes place as the object moves from point **C** to **D**. (1)
- 6.4.2 Calculate the acceleration that the object experiences as it moves from point **C** to **D**. (5)
- [17]**

QUESTION 7 (Start on a new page.)

- 7.1 The diagram below shows two waves, **A** and **B**, of the same wavelength but different amplitudes, crossing each other.

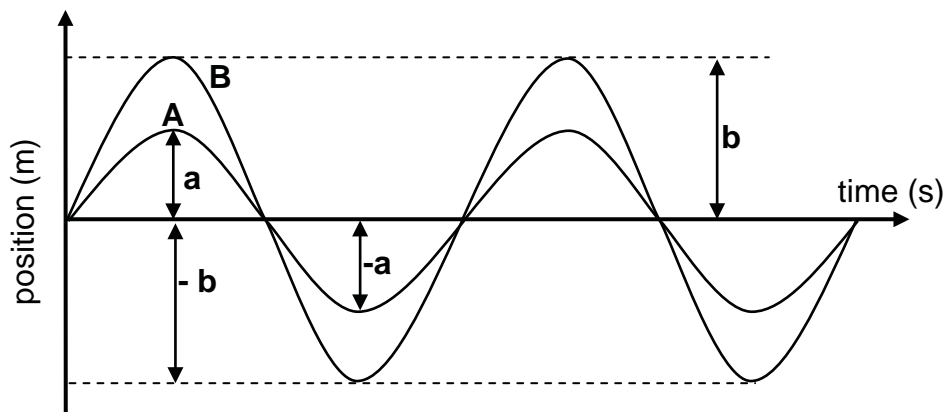

- 7.1.1 Define the term *amplitude*. (2)
- 7.1.2 Draw the shape of the resulting wave as the two waves (**A** and **B**) cross. On your diagram, show the resulting amplitude. (3)
- 7.1.3 Which wave property is illustrated in QUESTION 7.1.2? (1)
- 7.1.4 Name the principle used to answer QUESTION 7.1.2. (1)
- 7.2 In the sketch below, not drawn to scale, **Q** represents an object on the surface of the water in a dam. A person standing on a bridge observes object **Q** moving up and down. Object **Q** rises to the top every 5 s.

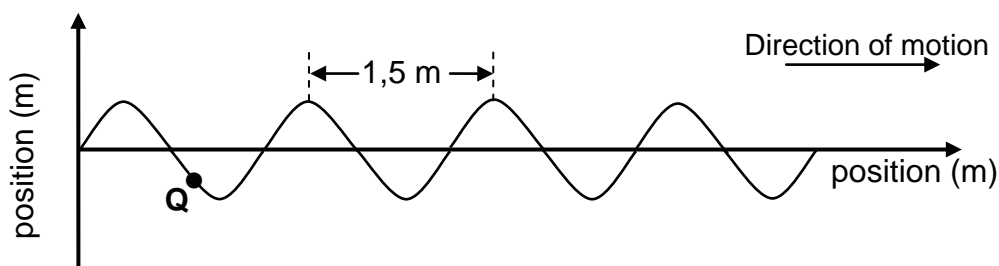

- 7.2.1 Define the term *wavelength*. (2)
- 7.2.2 In which direction is object **Q** about to move? (2)
- Calculate the:
- 7.2.3 Frequency of the waves (3)
- 7.2.4 Speed of the waves (3)
- [17]**

QUESTION 8 (Start on a new page.)

A sound wave produced by a vibrating musical instrument is represented in DIAGRAM 1 below.

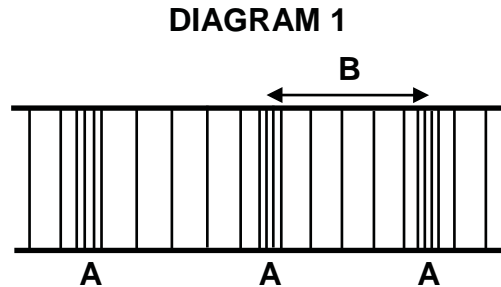

8.1 Label the sections marked:

8.1.1 A (1)

8.1.2 B (1)

8.2 The position-time graph in DIAGRAM 2 below represents the same sound wave produced by the musical instrument above.

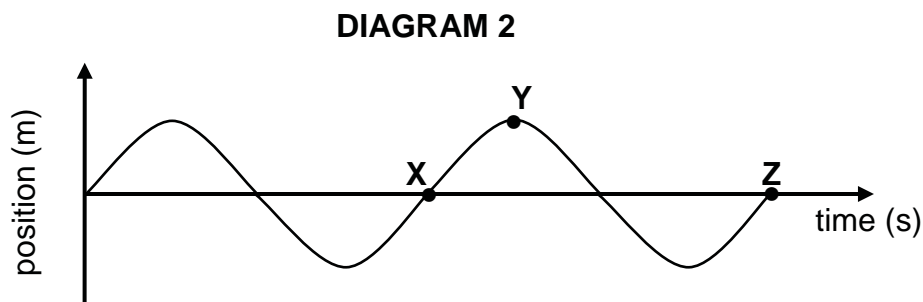

8.2.1 Name the type of wave represented in DIAGRAM 2. (1)

8.2.2 Which ONE of points X, Y or Z in DIAGRAM 2 corresponds to the section labelled A in DIAGRAM 1? (1)

8.2.3 *The same note is now played on the instrument, but much louder than before.*

How will this change affect the graph in DIAGRAM 2? (1)

8.2.4 *A note of higher frequency, but of the same original loudness is now played on the instrument.*

How will this change affect the graph in DIAGRAM 2? (1)

[6]

QUESTION 9 (Start on a new page.)

Some electromagnetic waves are listed below.

UV-rays Infrared rays Radio waves X-rays γ -rays

- 9.1 How are electromagnetic waves generated? (1)
- 9.2 From the list above, write down the waves:
- 9.2.1 Used in a TV remote control (1)
- 9.2.2 Used to sterilise instruments in hospitals (1)
- 9.2.3 With the greatest penetrating ability (1)
- 9.2.4 Used in the treatment of cancer (1)
- 9.3 Ultrasound is used to obtain an image of an unborn baby. Briefly explain why X-rays cannot be used for the same purpose. (2)
- 9.4 An X-ray photon incident on a body has a wavelength of $2,1 \times 10^{-9}$ m. Calculate how much energy the photon imparts to the body. (4)
- [11]**

QUESTION 10 (Start on a new page.)

- 10.1 In the diagram shown below steel paper clips **A** and **B** are attached to a string which is attached to a table. The paper clips remain suspended beneath a magnet.

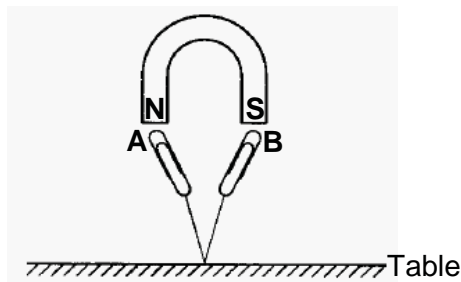

- 10.1.1 Define the term *magnetic field*. (2)
- 10.1.2 Will the top end of paper clip **A** be a N pole or a S pole? (1)
- 10.2 Two bar magnets are placed close to one another as shown in the diagram below.

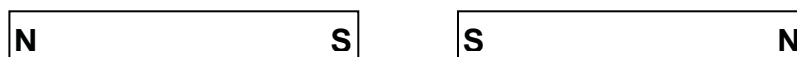

- 10.2.1 Draw the magnetic field pattern between the two magnets. (3)
- 10.2.2 The magnets are now moved further apart. What effect will this change have on the magnetic field pattern drawn in QUESTION 10.2.1? (1)

[7]

QUESTION 11 (Start on a new page.)

Two identical metal spheres, **A** and **B**, on an insulated surface carry charges of $-2,8 \times 10^{-6} \text{ C}$ and $+4,5 \times 10^{-6} \text{ C}$ respectively. The spheres are brought in contact with each other.

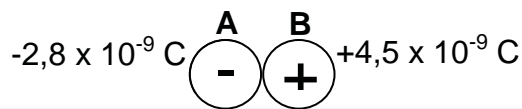

- 11.1 It is observed that the spheres move apart after contact. Briefly explain this observation. (3)
- 11.2 Calculate the new charge on each sphere after they moved apart. (3)
- 11.3 Calculate the number of electrons transferred from one sphere to the other during contact. (4)
- [10]**

QUESTION 12 (Start on a new page.)

Learners set up a circuit as shown in the diagram below. The emf of each cell is 1,5 V. Each of bulbs **A** and **B** has a resistance of 2Ω and bulb **C** has a resistance of 3Ω .

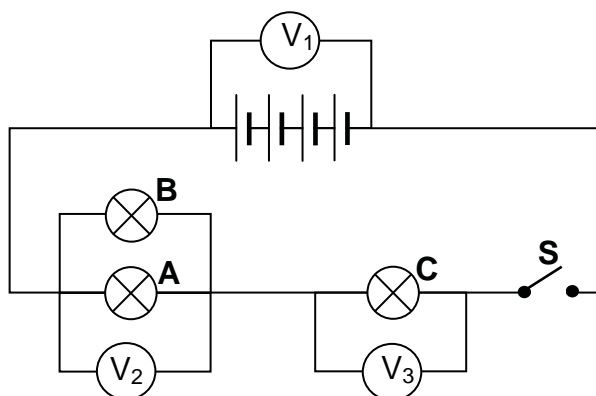

- 12.1 Calculate the effective resistance of bulbs **A** and **B**. (3)
- Switch **S** is now closed for a short time.
- 12.2 Determine the reading on:
- 12.2.1 Voltmeter V_1 (1)
- 12.2.2 Voltmeter V_3 (2)
- 12.3 Calculate the energy transferred in bulb **C** in 3 seconds if the current in the circuit is 2 A. (5)
- 12.4 ALL the bulbs are now connected in parallel. How will the total current in the circuit be affected? Write down only INCREASES, DECREASES or REMAINS THE SAME. (1)
- [12]**

GRAND TOTAL: 150

**DATA FOR PHYSICAL SCIENCES GRADE 10
PAPER 1 (PHYSICS)**

**GEGEWENS VIR FISIESTE WETENSAPPE GRAAD 10
VRAESTEL 1 (FISIKA)**

TABLE 1: PHYSICAL CONSTANTS/TABEL 1: FISIESTE KONSTANTES

NAME/NAAM	SYMBOL/SIMBOOL	VALUE/WAARDE
Acceleration due to gravity <i>Swaartekragversnelling</i>	G	9,8 m·s ⁻²
Speed of light in a vacuum <i>Spoed van lig in 'n vakuum</i>	C	3,0 x 10 ⁸ m·s ⁻¹
Planck's constant <i>Planck se konstante</i>	H	6,63 x 10 ⁻³⁴ J·s
Charge on electron <i>Lading op elektron</i>	e	-1,6 x 10 ⁻¹⁹ C
Electron mass <i>Elektronmassa</i>	m _e	9,11 x 10 ⁻³¹ kg

TABLE 2: FORMULAE/TABEL 2: FORMULES

MOTION/BEWEGING

$v_f = v_i + a \Delta t$	$\Delta x = v_i \Delta t + \frac{1}{2} a \Delta t^2$
$v_f^2 = v_i^2 + 2a \Delta x$	$\Delta x = \left(\frac{v_f + v_i}{2} \right) \Delta t$

WORK, ENERGY AND POWER/ARBEID, ENERGIE EN DRYWING

$U = mgh$ or/of $E_p = mgh$	$K = \frac{1}{2} mv^2$ or/of $E_k = \frac{1}{2} mv^2$
-----------------------------	---

WAVES, SOUND AND LIGHT/GOLWE, KLANK EN LIG

$v = f \lambda$	$T = \frac{1}{f}$
$E = hf$ or/of $E = h \frac{c}{\lambda}$	

ELECTRIC CIRCUITS/ELEKTRIESE STROOMBANE

$Q = I \Delta t$	$\frac{1}{R_p} = \frac{1}{R_1} + \frac{1}{R_2} + \dots$
$R_s = R_1 + R_2 + \dots$	$V = \frac{W}{q}$

ANSWER SHEET**LEARNER'S NAME:**1.1

A	B	C	D
---	---	---	---

1.2

A	B	C	D
---	---	---	---

1.3

A	B	C	D
---	---	---	---

1.4

A	B	C	D
---	---	---	---

1.5

A	B	C	D
---	---	---	---

1.6

A	B	C	D
---	---	---	---

1.7

A	B	C	D
---	---	---	---

1.8

A	B	C	D
---	---	---	---

1.9

A	B	C	D
---	---	---	---

1.10

A	B	C	D
---	---	---	---

For the use of the marker <i>Vir die gebruik van die nasiener</i>	
Marks obtained <i>Punte behaal</i>	
Marker's initials <i>Nasiener se paraaf</i>	
Marker's number <i>Nasiener se nommer</i>	

(10 x 2) **[20]**

GRAPH PAPER

LERANER'S NAME:

QUESTION 4.3

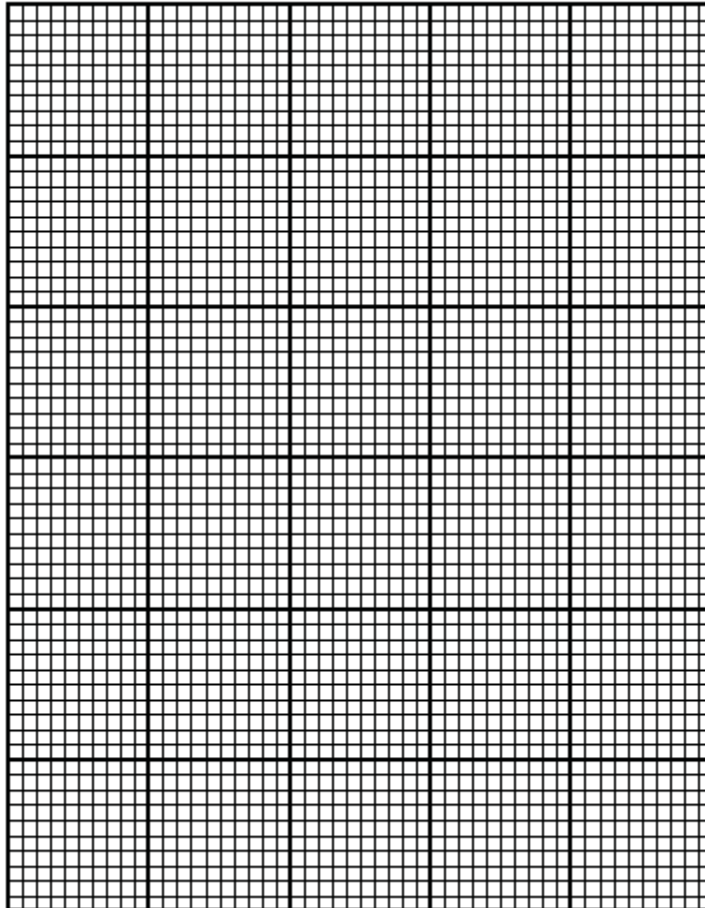

(6)